

7

Specifications

MODEL	SS-SWPB-60	SS-SWPB-120	SS-SWPB-300	SS-SWPB-600	SS-SWPB-1000
Outdoor detection range	15ft - 60ft	61ft - 120ft	121ft - 300ft	301ft - 600ft	601ft - 1000ft
Detection method	Twin beam infrared pulse , alarm only when all beams are broken.				
Response time	50ms				
Power input	solar energy				
Power consumption	200uA (the full charged system can work continuously more than 30 days without sunlight)				
LED indicator	1.flash 3 times when power on; 2.LED on in alarm condition;(receiver only); 3.Flash 1~9 times when alignment is successful.(receiver only).				
Buzzer	Receiver only 1.beep "dididi" when power on; 2.beep "di,di----"when alignment is successful, then stop beeping. 3. Beep "di" per 10 seconds when alignment is not successful.				
Alarm output	Wireless RF Transmission to Wireless Receiver SWPBR				
Frequency	315MHZ.				
RF range	2000 feet open area				
Tamper switch	Valid				
Alignment angle	vertical $10^{\circ}(\pm 5^{\circ})$, horizontal $180^{\circ}(\pm 90^{\circ})$				
Mounting	Wall mounting or pole mounting.				
Operation temperature	$-25^{\circ}\text{C}\sim 55^{\circ}\text{C}$ / $-13^{\circ}\text{F}\sim 131^{\circ}\text{F}$				
Weight	950g (Transmitter 1 pcs+Receiver 1 pcs+Accessories)				
Size	73mm X 85mm X 180mm / 2.874" X 3.3465" X 7.0866"				
Accessories	Wall mounting screw (4 pcs). Pole mounting screw (8 pcs).metal mounting bracket (2 pcs).mounting hook (4 pcs). View finder(2 pcs).U-clamp (4 pcs).				

8

Dimensions

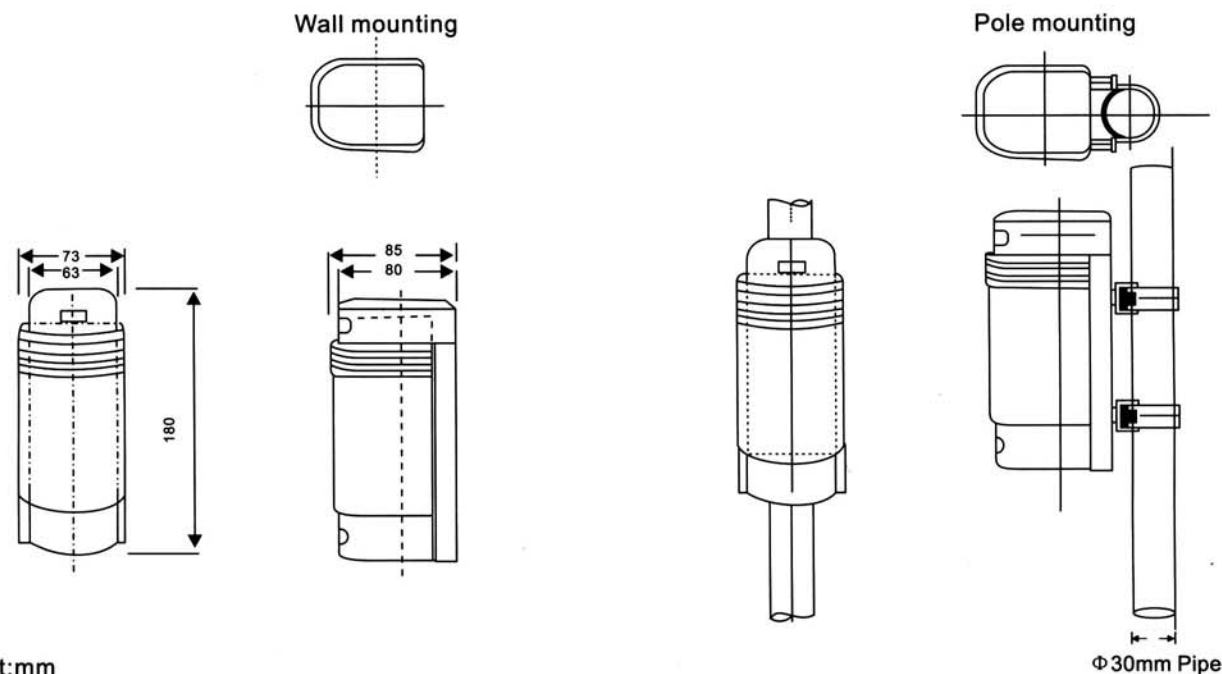

Solar Power Wireless Photobeam Sensor - Outdoor INSTRUCTION

- SS-SWPB-60 (detection range : 15ft - 60ft)
- SS-SWPB-120 (detection range : 61ft - 120ft)
- SS-SWPB-300 (detection range : 121ft - 300ft)
- SS-SWPB-600 (detection range : 301ft - 600ft)
- SS-SWPB-1000 (detection range : 601ft - 1000ft)

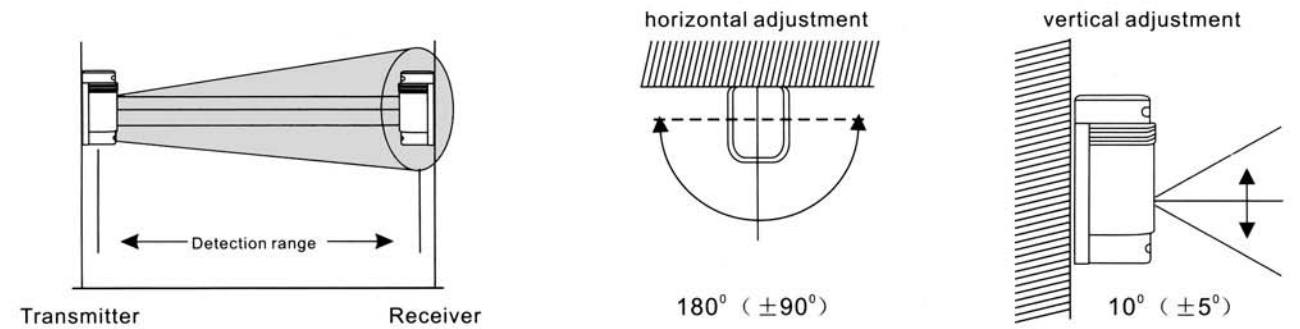

1

Positions Not Suitable for Installation

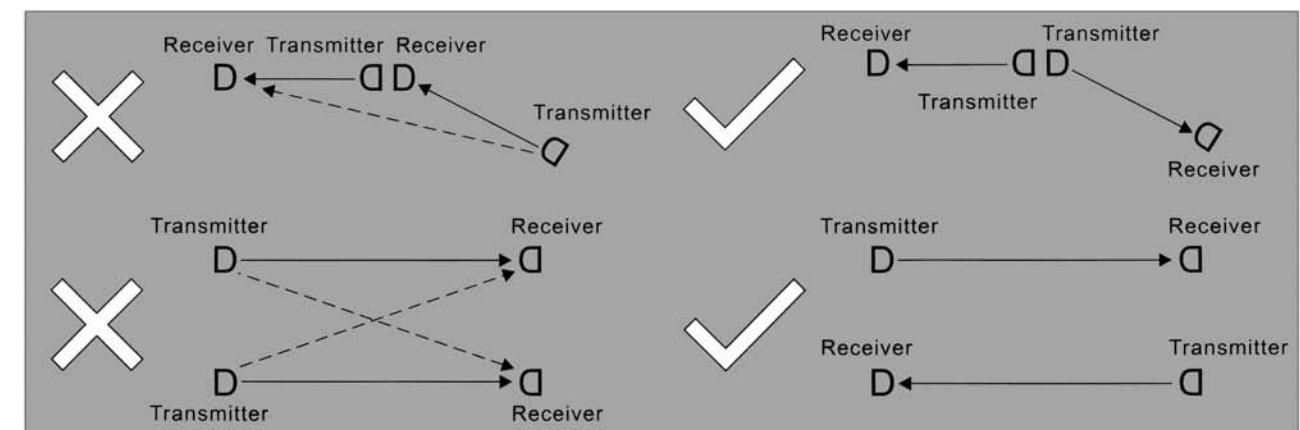
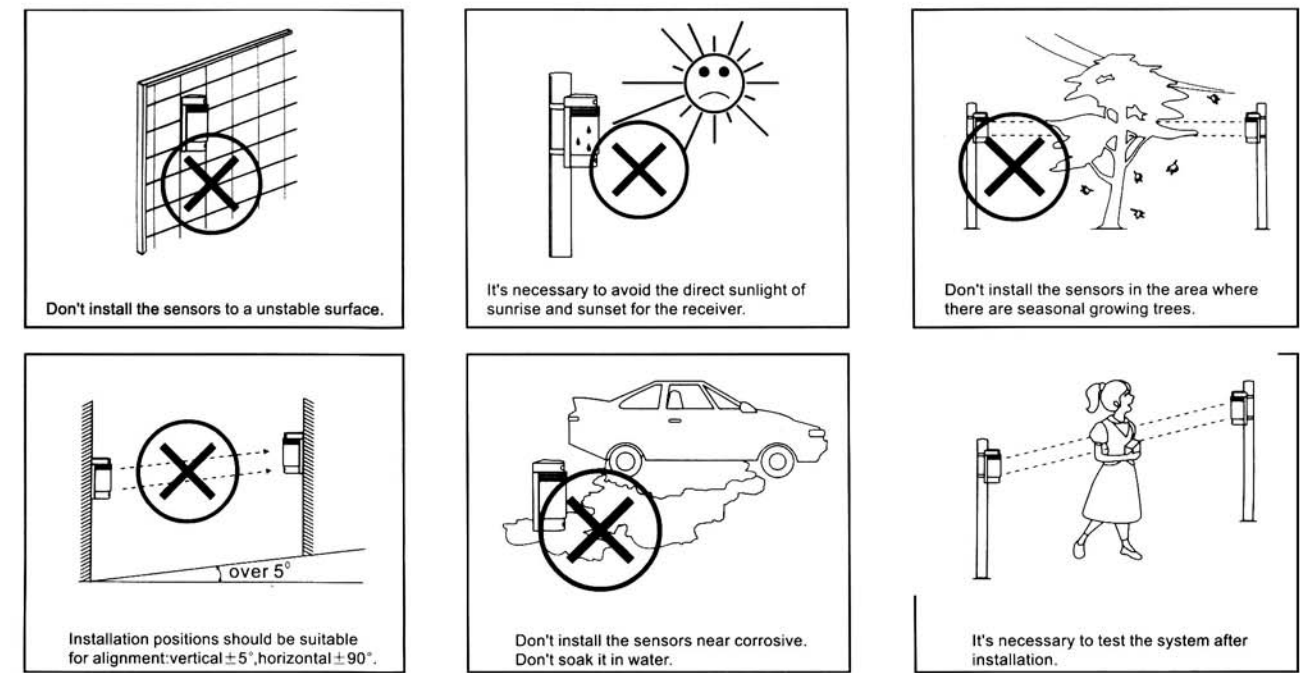

More couples of photobeam sensors can be used for long distance guard, please refer to the above figures to avoid mutual disturbance. When two couples JN-DCA are used in the same side. J1 jumper should be short-circuited for one of the two couples.

2 Parts Identification

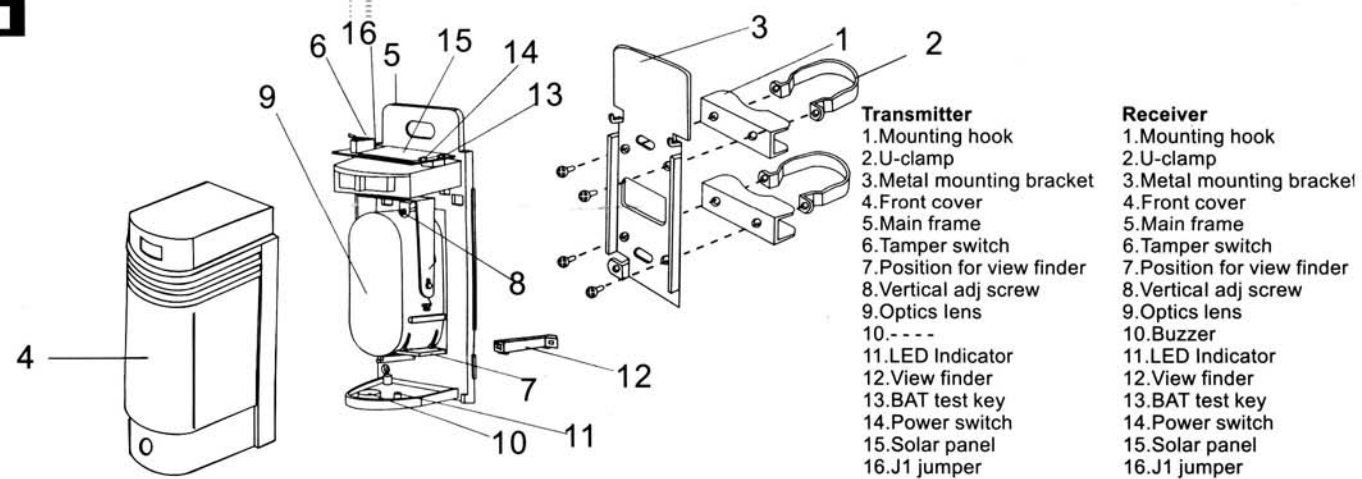

5 Methods to Clear Trouble

Trouble	Reason	Solution
LED indicator of the transmitter doesn't flash when power on.	The stored energy is not enough to support the system.	Press "BAT TEST" key to check if there is enough stored energy. If the LED is not lighted, put it under the sunlight and check it next day. Without the front cover, charging is quickly
LED indicator of the receiver doesn't flash and buzzer doesn't beep when power on.		
Detection range is not enough.	1. Alignment is not optimum. 2. Stored power is low.	1. Confirm proper installation of the view finder and optimize alignment with the test paper. 2. It will be all right after sunshine.
False alarm	1. Installation base is not stable.	1. Select a firm installation base against the wind.
	2. Alignment is not optimum.	2. Optimize alignment with the test paper.
	3. Battery power is low.	3. It will be all right after sunshine.
	4. Front covers are polluted.	4. Clean the front covers.
	5. There is some moving object between the transmitter and receiver.	5. Clear away the obstacle.
Alarm failure	1. The signal of the transmitter is reflected to the receiver.	1. Because of reflection, don't select long distance model for indoor use. Change the installation position of the transmitter to avoid reflection.
	2. Other transmitter's signal come into the receiver.	2. Change the other transmitter's installation position.
	3. Battery power is low.	3. It will be all right after sunshine.

3 Installation

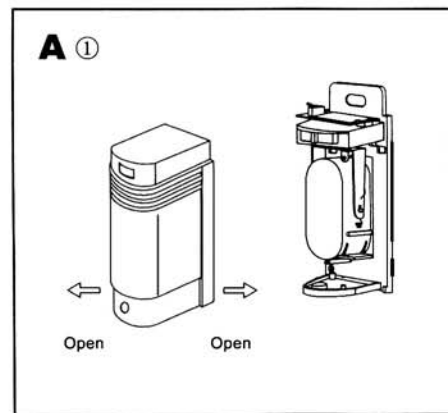

A. Wall Mounting

1. Pull the two bottom corners of the front cover outward and remove the front cover.
2. Unscrew the mainframe from the metal mounting bracket, then pull the mainframe upward.
3. Fix the metal mounting bracket to a wall with screws.

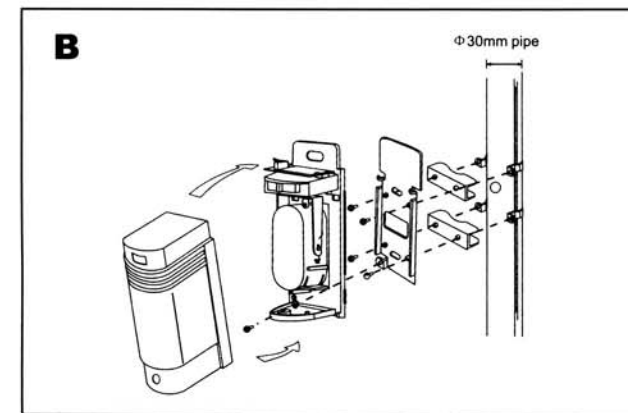
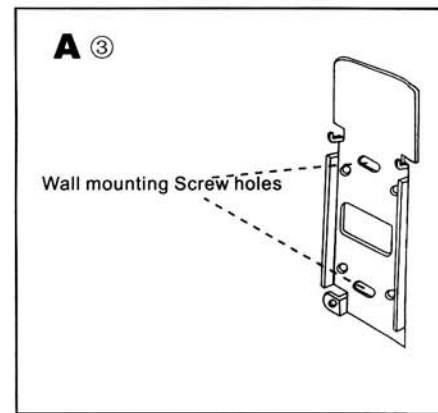
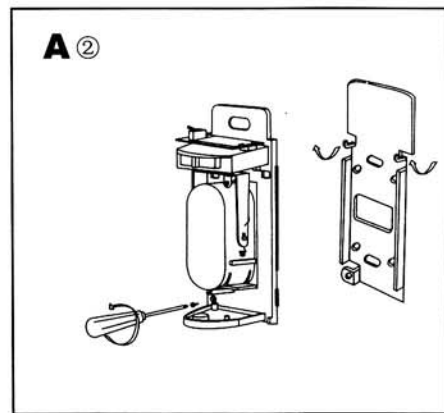

B. Pole Mounting

- The outer diameter of the mounting pole is About $\Phi 30\text{mm}$. Fix the metal mounting bracket, U-clamps and mounting hooks together tightly with screws. then install the mainframe to the metal mounting bracket.

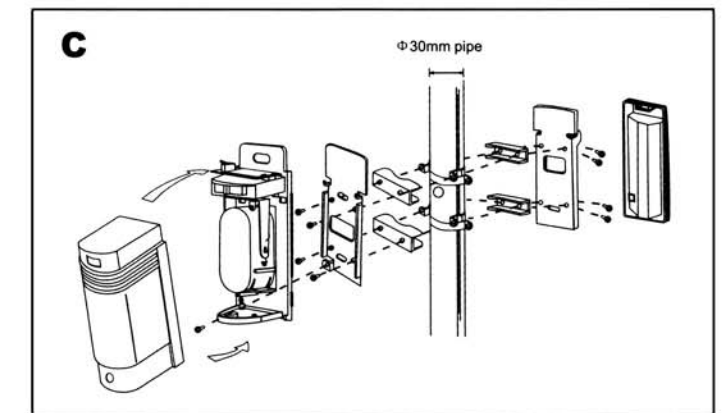

C. Back to Back Pole Mounting

- Fix two brackets to a pole with 4 couples of U-clamps and mounting hooks. refer to the above figure.

4 Alignment

Before installation, please refer to the operation instruction of JN2000-1 receiver to set a JN-DCA sensor as one zone of the JN2000-1 receiver.

1. Remove the front cover, and turn on the power switch, the LED indicator of the transmitter flashes 3 times. The receiver's LED indicator flashes 3 times and the buzzer beeps di, di, di.

2. Install the view finder as shown below and push it to the end.

3. Observe at an angle of 45°.

4. To make the photo of transmitter/receiver in the center of the view finder by vertical and horizontal adjustment. At first, adjust the transmitter, then adjust the receiver, the beep sound (di, di---) will be heard when alignment is successful. Put the test paper before the receiver and repeat alignment until the beep sound (di, di---) can be heard again after the two infrared beams are broken each time.

5. After successful alignment, remove the view finder, then install the front cover.

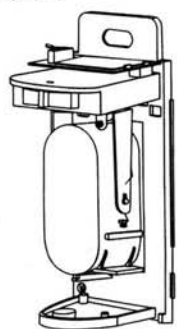

Figure 4-1

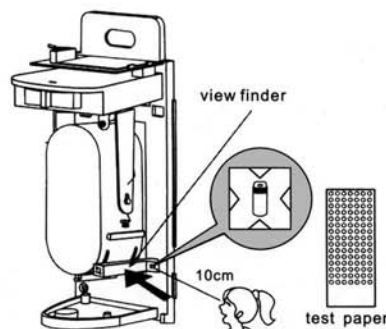

Figure 4-2

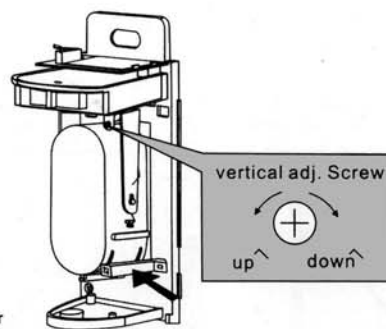

Figure 4-3

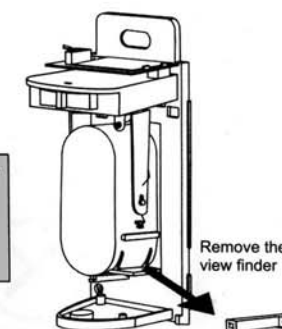

Figure 4-4

6 Options and Accessories



SS-SWPBR-4-1
4-Zone Non-Supervised Wireless Receiver with One Alarm Output



SS-SWPBREP-3
Solar Powered Wireless Signal Repeater



SS-SWPBR-AUX
Alert Monitor Wireless Receiver



SS-ESCELL
External Solar Cell Charger



VS-MCR-304
One Zone Fully Supervised Wireless Receiver



VS-MCR-308
4-Zone Fully Supervised Wireless Receiver